

Modular Cooking Range Line EVO900 2-Burner Gas Boiling Top, 7.5 kW - Town Gas

ITEM # _____

MODEL # _____

NAME # _____

SIS # _____

AIA # _____



392192 (Z9GCTD2Y0M)

2-burner (7,5 kW each) gas
boiling top - town gas

Short Form Specification

Item No. _____

To be installed on open base installations, bridging supports or cantilever systems. High efficiency flower flame burners with continuous power regulation and optimized combustion. Flame failure device as standard on burners to protect against accidental extinguishing. Exterior panels of unit in stainless steel with Scotch Brite finish. Pan supports in heavy duty stainless steel. Extra strength work top in heavy duty 2 mm stainless steel. Right-angled side edges to allow flush-fitting junction between units.

Main Features

- Unit to be mounted on open base cupboards, bridging supports or cantilever systems.
- The two 7.5 kW high efficiency burners are available in 100 mm diameter with continuous power regulation.
- Gas appliance supplied for use with town gas.
- Large sized pan support in cast iron (stainless steel as option) with long center fins to allow the use of the largest down to the smallest pans.
- Burners with optimized combustion.
- Flame failure device on each burner protects against gas leakage when accidental extinguishing of the flame occurs.
- Protected pilot light.
- The special design of the control knob system guarantees against water infiltration.
- IPX5 water protection.
- Suitable for countertop installation.

Construction

- All exterior panels in Stainless Steel with Scotch Brite finishing.
- AISI 304 stainless steel worktop, 2mm thick.
- Model has right-angled side edges to allow flush fitting joints between units, eliminating gaps and possible dirt traps.
- Pan supports in stainless steel.
- Unit is 900mm deep to give a larger working surface area.

APPROVAL: _____

Optional Accessories

- Junction sealing kit PNC 206086
- Draught diverter, 120 mm diameter PNC 206126
- Matching ring for flue condenser, 120 -130 mm diameter PNC 206127
- Support for bridge type installation, 800 mm PNC 206137
- Support for bridge type installation, 1000 mm PNC 206138
- Support for bridge type installation, 1200 mm PNC 206139
- Support for bridge type installation, 1400 mm PNC 206140
- Support for bridge type installation, 1600 mm PNC 206141
- Support for bridge type installation, 400 mm PNC 206154
- Side handrail for right/left hand PNC 206165
- Frontal handrail 400 mm PNC 206166
- Frontal handrail 800 mm PNC 206167
- Single burner smooth plate for direct cooking - fits frontal burners only PNC 206171
- Single burner ribbed plate for direct cooking - fits frontal burners only PNC 206172
- Large handrail (portioning shelf) 400 mm PNC 206185
- Large handrail (portioning shelf) 800 mm PNC 206186
- Frontal handrail 1200 mm PNC 206191
- Frontal handrail 1600 mm PNC 206192
- Pair of cast iron grids for gas ranges and boiling tops PNC 206208
- Water column with swivel arm (water column extension not included) PNC 206289
- Water column extension PNC 206290
- Stainless steel grid for 2 burners PNC 206298
- Chimney upstand, 400 mm PNC 206303
- Flue condenser for 1/2 module, 120 mm diameter PNC 206310
- 2 side covering panels, height 250 mm, depth 900 mm PNC 206321
- Wok pan support for open burners (EVO700/900) PNC 206363
- Kit town gas nozzles (G150) for EVO900 gas range PNC 206384
- Pressure regulator for gas units PNC 927225

Front

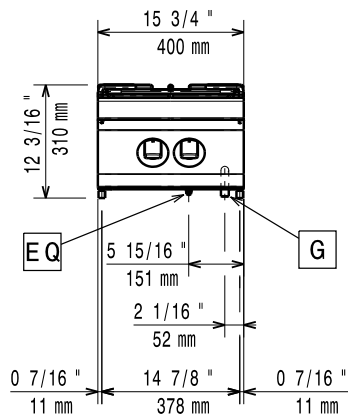

Side

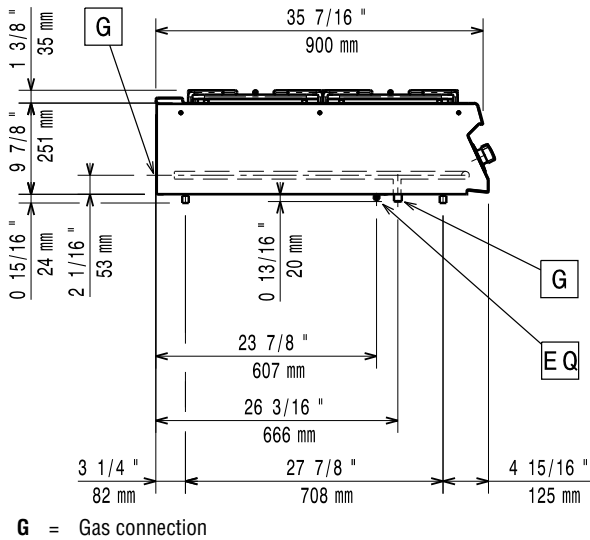

Top

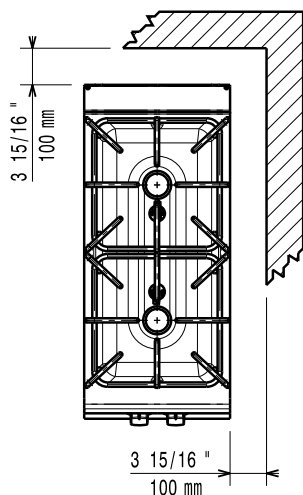

Gas

Gas Power:	
392192 (Z9GCTD2Y0M)	20 kW
Standard gas delivery:	Natural Gas G20 (20mbar)
Gas Type Option:	LPG;Town Gas
Gas Inlet:	1/2"

Key Information:

Front Burners Power:	7.5 - kW
Back Burners Power:	7.5 - 0 kW
Back Burners Dimension - mm	Ø 100
Front Burners Dimension - mm	Ø 100
Net weight:	43 kg
Shipping weight:	60 kg
Shipping height:	540 mm
Shipping width:	460 mm
Shipping depth:	1020 mm
Shipping volume:	0.25 m ³

If appliance is set up or next to or against temperature sensitive furniture or similar, a safety gap of approximately 150 mm should be maintained or some form of heat insulation fitted.

Certification group: N9CT